



Evaluation Report

CCMC 13319-R

MASTERFORMAT
Issued
Revised
Re-evaluation due

06 17 10
2008-07-02
2008-07-14
2011-07-02

LP[®] SolidStart[®] Laminated Strand Lumber

1. Opinion

It is the opinion of the Canadian Construction Materials Centre (CCMC) that “LP[®] SolidStart[®] Laminated Strand Lumber (LSL),” when used as structural composite lumber (SCL) in accordance with the conditions and limitations stated in Section 3 of this Report, complies with the National Building Code of Canada (NBC) 2005:

- Clause 1.2.1.1.(1)(a), Division A, as an acceptable solution required by Division B in:
 - Sentence 4.3.1.1.(1), (i.e. CSA O86(S1-05), Supplement #1 to CAN/CSA-O86-01, “Engineering Design in Wood,” for SCL qualification);
- Clause 1.2.1.1.(1)(b), Division A, as an alternative solution that achieves at least the minimum level of performance required by Division B in the areas defined by the objectives and functional statements attributed to the following applicable acceptable solution:
 - Sentence 9.23.4.2.(3) (i.e. beams and headers).

This opinion is based on CCMC’s evaluation of the technical evidence in Section 4.1 provided by the Report holder.

2. Description

“LP[®] SolidStart[®] LSL” is laminated strand lumber, which is a structural composite lumber manufactured from strands of wood species or species combinations blended with an isocyanate-based adhesive. The wood species strands are oriented in a parallel direction and formed into mats. The mats are pressed to the required thickness. “LP[®] SolidStart[®] LSL” is available in a range of thicknesses (133 mm (5-1/4”) maximum), depths and lengths.

The manufacturing quality assurance program and records are verified by APA-The Engineered Wood Association as part of the product certification.

Figure 1 illustrates the strand orientation of “LP[®] SolidStart[®] LSL.”

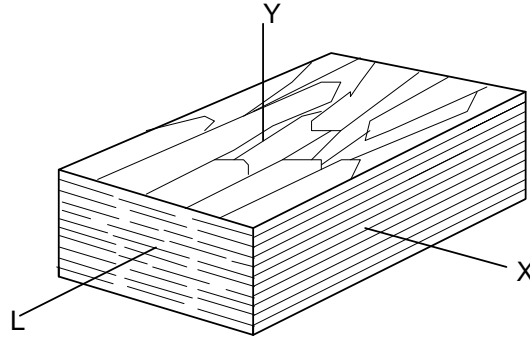

Figure 1. A block of “LP® SolidStart® LSL” illustrating strand orientation.

3. Conditions and Limitations

CCMC’s compliance opinion in Section 1 is bound by the “LP® SolidStart® LSL” being used in accordance with the conditions and limitations set out below.

“LP® SolidStart® LSL,” as with all SCL, is intended for dry service applications only.⁽¹⁾

“LP® SolidStart® LSL” is intended for use in construction as an alternative material to lumber. Proprietary design values are presented for “LP® SolidStart® LSL” to be designed by professional engineers in accordance with CAN/CSA-O86-01 for structural applications such as beams, headers, joists, rafters and columns as intended by the product manufacturer. The specific application must be qualified through specific testing and validated by the manufacturer for the specific use. For applications such as I-joist flanges, studs, rimboards and metal-plated truss chords, these are beyond the scope of this evaluation.

(1) All lumber, wood-based panels and proprietary engineered wood products are intended for “dry service conditions.” “Dry service” is defined as the in-service environment under which the equilibrium moisture content (MC) of lumber is 15% or less over a year and does not exceed 19% at any time. Wood contained within the interior of dry, heated or unheated buildings has generally been found to have a MC between 6% and 14% according to season and location. During construction, all wood-based products should be protected from the weather to ensure that the 19% MC is not exceeded in accordance with the NBC 2005, Division B, Article 9.3.2.5.

The pre-engineered tables in the literature outlined below has been provided to CCMC by Louisiana-Pacific Corp. to demonstrate compliance to Part 9 buildings for acceptance by the local authority having jurisdiction (AHJ):

i) “LP® SolidStart® LSL’s” Pre-engineered Tables⁽²⁾

When “LP® SolidStart®” LSL is used as roof and floor beams, headers, in simple or continuous spans, roof rafters and roof lintels, supporting uniform loads only, the installation must be in accordance with the tables and installation details published by Louisiana-Pacific Corp. entitled:

- “LP® SolidStart® LSL Beam and Header Technical Guide - Limit States Design,” dated 08/08.

“LP® SolidStart®” LSL shall be installed in accordance with Louisiana-Pacific Corp.’s installation guidelines noted in the above-mentioned documents for those applications falling within the scope of the documents. Applications outside the scope of these installation guidelines shall require engineering on a case-by-case basis.

(2) *The pre-engineered Tables present the pre-engineered factored resistance of the beam. The AHJ may require further engineering to determine the factored load in accordance with the NBC 2005, Division B, Part 4.*

(3) *As per the NBC 2005, Division B, Section 9.4., particularly in areas of high wind and high seismicity, the adequacy of the rim board to transfer loads from shear walls and the diaphragm must be verified.*

ii) Louisiana-Pacific Corp.’s Installation Details

Louisiana-Pacific Corp.’s pre-engineered details within the documents outlined in 3(i) above are limited in scope to building designs where the anticipated loads on the following structural details will not be exceeded:

- window and door headers;
- headers supporting roof;
- ridge beams;
- headers supporting floor and roof;
- floor girder beams;
- specified hanger factored resistances;
- bearing length details;
- nail spacing;
- allowable holes;
- multiple member connections; and
- column details

iii) Engineering Required

For structural applications beyond the scope/limitations of the above-referenced Louisiana-Pacific’s publications or when required by the AHJ, the drawings or related documents shall bear the authorized seal of a professional engineer skilled in wood design and licensed to practice under the appropriate provincial or territorial legislation.

Installations beyond the scope/limitations of 3(i) and 3(ii) imply, but are not limited to, the following:

- higher loads/longer spans than the manufacturer’s pre-engineered details;
- concentrated loads;
- areas of high wind or high seismicity;
- design of supporting members/columns when the total beam/header load exceeds the NBC 2005 pre-engineered beam/lintel tables; and
- design of supporting foundation footings when the total load exceeds the NBC 2005 pre-engineered floor/roof joist tables.

The engineer shall design in accordance with CAN/CSA-O86-01, and may use as a guide, the “Engineering Guide for Wood Frame Construction,” published by the Canadian Wood Council.

The specified strengths for “LP[®] SolidStart[®] LSL” shall not exceed the values set forth in Table 4.1.1. See Figure 1 for details about strand orientation.

Nailing of “LP[®] SolidStart[®] LSL” perpendicular to the wide face of strand (WFS) shall conform to the NBC 2005, Division B, Table 9.23.3.4. Edge nailing of “LP[®] SolidStart LSL” parallel to the WFS shall conform to Table 4.1.2. Basic nail, bolt and lag screw capacities shall be as shown in Table 4.1.2.

The ends of all “LP[®] SolidStart[®] LSL” members used as joists, rafters and beams shall be restrained to prevent rollover. This is normally provided by diaphragm sheathing attached to the top or the compression edge, and an end wall or shear transfer panel capable of transferring a minimum unfactored uniform load of 730 N/m or the required shear forces due to wind or seismic conditions. Blocking or cross-bracing with equivalent strength may be used.

The compression edges of all “LP[®] SolidStart[®] LSL” members used as joists, rafters and beams shall be laterally supported at least every 610 mm, except where design is done in accordance with CAN/CSA-O86-01.

iv) Engineering Support Provided by Manufacturer

Louisiana-Pacific Corp. provides engineering support through either Taiga Forest Products or a professional engineer skilled in wood design and licensed to practice under the appropriate provincial or territorial legislation. Louisiana-Pacific Corp. may also be consulted in the use of “LP[®] SolidStart[®] LSL”.

Taiga Forest Products (tech. support): (905) 858-1300
mmerhar@taigabuilding.com

Louisiana-Pacific Corp. (tech. support): (888) 820-0325
customer.support@lpcorp.com

“LP[®] SolidStart[®] LSL” products must be identified with the phrase “CCMC 13319-R” on the products. This CCMC number is only valid when it appears in conjunction with the certification mark of APA-The Engineered Wood Association.

4. Technical Evidence

CCMC’s Technical Guide for “Structural Composite Lumber” sets out the nature of the technical evidence required by CCMC to enable it to evaluate a product as an alternative solution in compliance with the NBC 2005. The Report holder has submitted test results for CCMC’s evaluation. Testing was witnessed by an independent testing agency recognized by CCMC. The corresponding test results for “LP[®] SolidStart[®] LSL” are summarized below.

4.1 NBC 2005 Compliance Data for “LP® SolidStart® LSL” on which CCMC Based its Opinion in Section 1

Table 4.1.1. Specified Strengths⁽¹⁾⁽²⁾⁽³⁾⁽⁴⁾ for “LP® SolidStart® LSL”

Grade	Modulus of Elasticity ⁽⁷⁾ MPa (x10 ⁶ psi)	Beam Orientation			Plank Orientation			Axial	
		Bending ⁽⁵⁾ F _b MPa (psi)	Shear F _v MPa (psi)	Compr. Perp. to Grain, F _{c⊥} MPa (psi)	Bending F _b MPa (psi)	Shear F _v MPa (psi)	Compr. Perp. Grain, F _{c⊥} MPa (psi)	Tension ⁽⁶⁾ F _t MPa (psi)	Compr. F _{c//} MPa (psi)
1730F _b -1.35E	9 310 (1.35)	22.05 (3 195)	5.25 (760)	9.40 (1 365)	24.35 (3 530)	2.00 (290)	5.50 (800)	13.95 (2 020)	18.15 (2 635)
2360F _b -1.55E	10 690 (1.55)	30.05 (4 360)	5.25 (760)	11.00 (1 595)	33.40 (4 820)	2.00 (290)	5.50 (800)	18.70 (2 715)	23.90 (3 470)
2640F _b -1.75E	12 070 (1.75)	33.65 (4 880)	5.25 (760)	11.95 (1 730)	37.10 (5 375)	2.00 (290)	5.50 (800)	23.05 (3 350)	26.95 (3 910)

Notes to Table 4.1.1:

- (1) All values are in accordance with CSA O86-01(S1-05).
- (2) Specified strengths are for standard term load duration and may be adjusted (with the exception of modulus of elasticity) using load duration factor in accordance with the CSA O86-01(S1-05).
- (3) Specified bending stresses shall apply to product installation conditions of use that are dry, well ventilated interior applications in which the equivalent moisture content of lumber would not exceed 15%.
- (4) The specified strengths for “Beam” refer to applied parallel to the wide face of the strands (the edge of the member). “Plank” refers to loads applied perpendicular to the wide face of the strands (the face of the member). See Figure 2 for the loading direction with respect to the strand orientation.
- (5) The specified “Beam” bending strength, F_b, is based on a standard depth of 305 mm (12 in.). For other depths, multiply F_b by (305/depth in mm)^{0.143}.[(12/depth in in.)^{0.143}] For depths less than 69 mm, multiply F_b by 1.192.
- (6) The specified tension strength, F_t, is assigned for a standard length of 6 096 mm (20 ft.). For other lengths, multiply F_t by (6 096/length in mm)^{0.092}.[(20/length in ft)^{0.092}] For lengths less than 914 mm (3 ft.), use the design tensile stresses adjusted to 914 mm (3 ft.).
- (7) The modulus of elasticity is shear-free. Therefore, when calculating deflection, both bending and shear deformations must be included. The following equation may be used for a simple supported loading condition under uniform load:

$$\Delta = \frac{5wL^4}{384EI} + \frac{2.4wL^2}{Ebd}$$

- where:
- Δ = deflection (mm)
 - w = specified uniform load (N/mm)
 - L = span (mm)
 - E = modulus of elasticity (shear-free) (MPa)
 - I = moment of inertia (mm⁴)
 - b = beam width (mm)
 - d = beam depth (mm)

Table 4.1.2. Equivalent Specific Gravity for “LP® SolidStart® LSL” Fastener Design⁽¹⁾⁽²⁾

Grade	Equivalent Specific Gravity					
	Nails				Bolts Installed in Face ⁽³⁾	
	Withdrawal Load		Lateral Load		Lateral Load	
	Installed in Edge	Installed in Face	Installed in Edge	Installed in Face	Load Applied // to Grain	Load Applied ⊥ to Grain
1730Fb-1.35E And Above	0.46	0.50	0.50	0.55	0.50	0.58

Notes to Table 4.1.2:

- (1) Fastener sizes and orientation not specifically described above are beyond the scope of this Evaluation Report. See CAN/CSA-O86-01(S1-05), Table A10.1, for equivalent species based on relative density (specific gravity).
- (2) Fastener values based on the equivalent specific gravities in the above table are for standard term load duration and may be adjusted using load duration factors as per the CAN/CSA-O86-01(S1-05).
- (3) The edge distance, when loaded parallel and perpendicular to the grain shall be a minimum of four times the bolt diameter.

Table 4.1.3. Nail Spacing⁽¹⁾⁽²⁾ Requirements for “LP® SolidStart® LSL”

Thickness mm (in.)	Orientation	Fastener ⁽³⁾⁽⁵⁾⁽⁶⁾⁽⁷⁾	Minimum End Distance ⁽⁴⁾ mm (in.)	Minimum Nail Spacing mm (in.)
≥ 32 (≥ 1-1/4)	edge	64 mm and smaller (8d and smaller)	51 (2)	76 (3)
		76 mm and 83 mm (10d and 12d)	51 (2)	76 (3 ½)
		89 mm (16d)	63 (2 ½)	89 (3 ½)
	face	64 mm and smaller (8d and smaller)	22 (7/8)	25 (1)
		76 mm and 83 mm (10d and 12d)	22 (7/8)	25 (1)
		89 mm (16d)	22 (7/8)	38 (1 ½)

Notes to Table 4.1.3:

- (1) Minimum nail spacing for the face orientation is applicable to nails that are installed in rows that are parallel to the direction of the grain (length) of the strand lumber. For nails in face installed in rows that are perpendicular to the direction of the grain (width/depth) of the strand lumber, the minimum nail spacing for the face orientation shall be as per CAN/CSA-O86-01(S1-05).
- (2) Fastener sizes and minimum nail spacing not specifically described above are beyond the scope of this Evaluation Report.
- (3) Fasteners are common wire or common spiral nails.
- (4) Edge distance shall be sufficient to prevent splitting but not less than permitted in CAN/CSA-O86-01.
- (5) Nail penetration for edge nailing shall not exceed 51 mm (2 in.) for 89-mm (16d 3-1/2-in.) nails and 64 mm (2-1/2 in.) for 76-mm (10d 3-in.) and 83-mm (12d 3-1/4-in.) nails.
- (6) For multiple rows of nails, the rows must be offset 13 mm (1/2 in.) or more from each other, and staggered.
- (7) For multiple rows of nails, rows must be equally spaced from the centerline of the product edge or face (whichever applies).

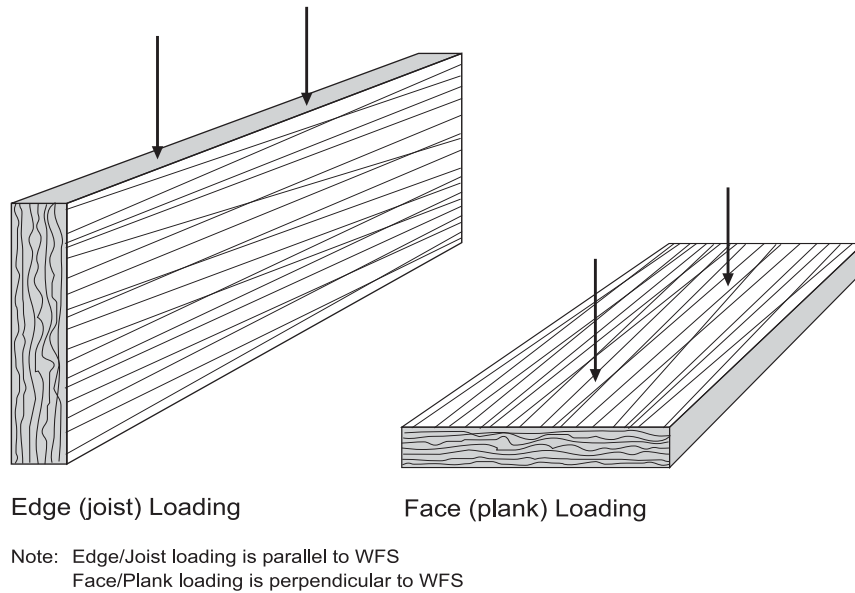

Figure 2. Load direction with respect to strand orientation.

Report Holder: Louisiana-Pacific Corporation
2706 Highway 421 North
Wilmington, North Carolina
USA 28401

Tel.: (910) 762-9878
Fax: (910) 763-8178

Plant: Houlton, ME, USA

This Report is issued by the Canadian Construction Materials Centre, a program of the Institute for Research in Construction at the National Research Council of Canada. The Report must be read in the context of the entire CCMC Registry of Product Evaluations, including, without limitation, the introduction therein which sets out important information concerning the interpretation and use of CCMC Evaluation Reports.

Readers must confirm that the Report is current and has not been withdrawn or superseded by a later issue. Please refer to <http://irc.nrc.gc.ca/ccmc>, or contact the Canadian Construction Materials Centre, Institute for Research in Construction, National Research Council of Canada, 1200 Montreal Road, Ottawa, Ontario, K1A 0R6. Telephone (613) 993-6189. Fax (613) 952-0268.

NRC has evaluated the material, product, system or service described herein only for those characteristics stated herein. The information and opinions in this Report are directed to those who have the appropriate degree of experience to use and apply its contents. This Report is provided without representation, warranty, or guarantee of any kind, expressed, or implied, and the National Research Council of Canada (NRC) provides no endorsement for any evaluated material, product, system or service described herein. NRC accepts no responsibility whatsoever arising in any way from any and all use and reliance on the information contained in this Report. NRC is not undertaking to render professional or other services on behalf of any person or entity nor to perform any duty owed by any person or entity to another person or entity.

APPENDIX

The design values obtained from testing to ASTM D 5456-01, “Standard Specification for Evaluation of Structural Composite Lumber Products,” as specified in CAN/CSA-O86-01 are summarized below.

Table A1. Additional Test Information for “LP® SolidStart® Strand Lumber”

Property	Test Information
Bending	Specimens were tested in edgewise and flatwise bending to establish the characteristic value. Qualification test data have been used to establish the applicable coefficient of variation, CV_w , and the reliability normalization factor from CAN/CSA-O86-01 was used to determine the specified strength.
Shear	Specimens were tested in shear to establish the characteristic value. Qualification test data have been used to establish the applicable coefficient of variation, CV_w , and the reliability normalization factor from CAN/CSA-O86-01 was used to determine the specified strength.
Compression parallel to grain	Specimens were tested in compression parallel to grain to establish the characteristic value. Qualification test data have been used to establish the applicable coefficient of variation, CV_w , and the reliability normalization factor from CAN/CSA-O86-01 was used to determine the specified strength.
Compression perpendicular to grain	Specimens were tested in compression perpendicular to grain to establish the characteristic value. The characteristic value was multiplied by 1.09 to establish the specified strength in accordance with CAN/CSA-O86-01.
Tension parallel to grain	Specimens were tested in tension to establish the characteristic value. Qualification test data have been used to establish the applicable coefficient of variation, CV_w , and the reliability normalization factor from CAN/CSA-O86-01 was used to determine the specified strength.
Nail withdrawal	Nail withdrawal values were established following ASTM D 1761, “Standard Test Methods for Mechanical Fasteners in Wood,” for an 8d common nail having a 31.75-mm penetration. Specimens were tested and equivalent species capacity was determined in accordance with ASTM D 5456-98, A2.4
Nail bearing	Dowel bearing strength was determined as per ASTM D 5764-95, “Standard Test Method for Evaluating Dowel-Bearing of Wood and Wood-Based Products,” with 10d common nails with a nominal diameter of 3.76 mm and a lead hole diameter of 2.77 mm. Specimens were tested and the mean bearing capacity was used to establish the equivalent species capacity as per ASTM D 5456-98, A2.5.
Bolt bearing	Bolt bearing capacity was determined in accordance with ASTM D 5764-95 with 12.5-mm and 19.0-mm bolts. Specimens were tested and the mean bolt bearing capacity was used to establish the equivalent species capacity as per ASTM D 5456-98, A2.5.
Creep	A total of 53 specimens were tested and a 90-day creep assessment was also conducted in accordance with ASTM D 5456-98 and ASTM D 6815-02a, “Standard Specification for Evaluation of Duration of Load and Creep Effects of Wood and Wood-Based Products.” It demonstrated equivalency to the duration of load behaviour of sawn lumber.
Adhesive	The binder meets CSA O437.2-93, “Evaluation of Binder Systems for OSB and Waferboard,” with modifications. In addition, after a 14-day soak conditioning, the LSL specimens with equivalent MDI binder were submitted to the 90-day creep test of ASTM D 6815 and performance equivalent to lumber was demonstrated.